

Industrial audit, design,  
manufacture and installation



# Plastic tanks

and installations







## Amargo Tank Think Tank

Our mission is the responsible implementation of industrial installations. As a team of experts (think tank) in plastic tanks, we are able to meet the technical challenges, legal requirements and trends posed to companies by the changing reality. We provide complete solutions, thought through from the very beginning of the project and executed at the highest level. We confidently step in where the scale of the challenge surpasses others.

Szczepan Gorbacz, Amargo CEO

## Contact information

AMARGO Sp. z o.o. Sp. k.  
Jaśminowa 16 Street, Koparki  
05-850 Ożarów Mazowiecki, Poland  
NIP (tax ID): 1182029374  
REGON no.: 142379794

 office: +48 798 087 353  
 [www.amargo.pl/en](http://www.amargo.pl/en)

### CUSTOMER SERVICE

 [eksperci@amargo.pl](mailto:eksperci@amargo.pl)  
 +48 798 775 760

## Contents

About us	
Competencies of our team .....	4
We create solutions that respond to market challenges and the current economic situation ...	8
We are a partner for our clients and support them from the concept stage .....	9
Heart of Amargo – plastic tanks are manufactured here .....	10
Audit, concept, design .....	12
Tanks and installations	
Chemical resistant aboveground tanks .....	13
Comprehensive industrial installations .....	20
Chemical resistant tanks – case studies .....	22
Indoor modular water storage tanks .....	25
Water storage tanks – case studies .....	29
Underground pipe tanks .....	31
Service of tanks and installations .....	32
Chemical protection .....	33
Cylinders, plastic pipes – mass production .....	34
Tank Education TAED Academy .....	35

# Competencies of our team

We are a consulting and manufacturing company whose key activities include consulting and audits (including case studies, feasibility studies, budgeting), design, manufacture and installation of chemical resistant tanks and water tanks along with complete industrial installations.

**According to us, the most important thing is to get to know the customer's situation, the conditions of his installation and needs, and then to select an adequate solution - so that the new installation will be optimal, safe and work trouble-free for many years.**

As part of the investment, we provide:

- audits, feasibility studies and technical consulting,
- development of technical and detailed designs for tanks and installations, including 3D modeling,
- development of control and automation installation design,
- manufacturing of the tank and execution of associated installations,
- delivery and installation at the facility,
- equipping with necessary fittings,
- tank servicing,
- comprehensive formal and legal services.



## Competence confirmed by a UDT certificate

We carry out the work in accordance with current standards, regulations and authorizations of the Office of Technical Inspection (UDT) for the manufacture, modernization and repair of non-pressure and low-pressure tanks – both of thermoplastics and composites – for poisonous or corrosive media and flammable liquids. Our employees are trained and certified by accredited centers.



## Experience in the “design and build” formula

We successfully implement investments in the “design and build” model. We carry out design studies on our own or in cooperation with external design offices and providers of specialized services. In our hands is often general contracting. Such a formula significantly shortens the investment process, as well as removes a number of responsibilities from you – the Investor – and reduces the risk.



## In-house laboratory and R&D department

For more than 19 years, we have been deepening our knowledge and experience and constantly improving our machinery. We have an excellently equipped quality control department (strength machine, plastometer, ultrasonic testing and others). We continuously invest in new technologies, R&D department and laboratory, and expand the scope of production and applied methods of processing thermoplastics and composites.



## Sharing expert, practical knowledge

We are practitioners, and our overarching goal is to share knowledge and inspire the implementation of the best solutions affecting the safe storage of chemicals or water. We not only want to spread knowledge about possible new solutions for advanced plastic applications, but also to raise the culture of plastic tank operation among future users.



## Cooperation with the scientific community and industry experts

Together with scientific institutions, we carry out research and development projects in the development of new technologies. We cooperate with the Łukasiewicz Research Network Institutes, Poznań Science and Technology Park and other domestic and foreign centers. We work very closely with Wrocław University of Technology and Warsaw University of Technology, including within the framework of the Warsaw University of Technology Career Office. Amargo's CEO is also a Mentor in the PW Mentoring Program.



## Active membership in industry organizations

Within the framework of membership in, among others, the Polish Chamber of Chemical Industry, Polish Composite Technology Cluster, Wielkopolska Hydrogen Platform, Bydgoszcz Industrial Cluster, Hydrogen Center Platform, Pilot Hydrogen (H<sub>2</sub>), and in cooperation with the Office of Technical Inspection or the Technical Committee of the Polish Committee for Standardization, we actively participate in discussions about both new technologies and correlation of technical solutions with regulations.



## Awards and nominations for innovation

Innovative thinking is extremely important in our work. However, we do not stop at thinking and consistently translate it into innovative projects. Our work is being recognized. In 2022, we received an award in the Innovator of Mazovia competition and a nomination for “Product innovations at Amargo developed through the creation of R&D infrastructure.” This motivates us to continue creating innovative technologies.

# We create solutions that respond to market challenges and the current economic situation

According to the latest data for the European Union, verified by Eurostat (Manufacturing Statistics), the manufacturing industry remains in a phase of growth and development. Due to its energy intensity and generation of a high environmental burden, responsible management of manufacturing infrastructure is required.

Nowadays, many manufacturing plants are striving to become more competitive and maintain good financial performance. The Industry 4.0 model

therefore generates challenges such as new investments, skills, technology and safety. Industry 5.0, on the other hand, puts people at the center of the manufacturing process. Technological solutions for human-machine interaction, creation of digital twins, transmission, storage and analysis of data or artificial intelligence are becoming important.

Therefore, innovative solutions responding to increasing digitization and robotization are very

much needed and sought after in this market – outdated solutions are no longer sufficient.

In our cooperation, we always strive for the best understanding of the exact problems you face, your vision and the goal you want to achieve. We are aware of changing regulations and new trends in sustainability, which is why we also implement heat, energy, factor recovery systems as part of a closed loop economy or carbon footprint reduction.



Improve production and personnel safety



Optimization of costs of implemented processes



Modernize production and implement automation



Development plans, quality improvement and production growth



Maintaining the continuity of production processes



Protecting the environment and increasing energy efficiency



# We are a partner for our clients and support them from the concept stage

Knowledge of tanks, especially for chemicals, is specialized, and selecting the right solutions is extremely important at the early stages of a project. This avoids basic mistakes. That's why, in such cases, it's a good idea to start discussions at the stage when you're really just considering the investment, i.e. envisioning possible solutions to your problem or the realization of new challenges, reviewing cost estimates and evaluating budget possibilities or potential return on investment over time. This is a very intuitive step that will allow you to prepare properly and eliminate the risk of mistakes in later phases.

We provide our customers with complete solutions that can be used in almost any industry, meeting even the most stringent requirements. The high quality of raw materials used in production allows for safe and reliable operation of tanks and installations for many years, in accordance with the principles of sustainable development.

**We carry out tasks for many industrial sectors (either directly or in cooperation with design offices):** heavy industry, power industry (thermal power plants), pharmaceutical industry, petrochemical industry, chemical industry, paint and

varnish industry, food industry (including breweries, beverage producers), pulp and paper industry, textile industry, metallurgical industry, metallurgical industry, tire industry, water treatment plants, water supply plants and sewage treatment plants.

**In addition to industry, we realize tanks designed for use in public facilities:** health centers (hospitals, hospices, care and treatment facilities, rehabilitation centers, spas, sanatoriums), hotels, boarding houses, schools, multi-family buildings (blocks of flats, high-rise buildings, townhouses) or religious buildings.



# Heart of Amargo – plastic tanks are manufactured here

We are constantly investing in the development of our technological facilities – all in order to provide solutions that meet the most stringent standards (both current and future). The best example is the 2,300-square-meter production hall built in 2021, which reaches a height of 20 meters. With four overhead cranes with a lifting capacity of up to 20 t, we have the ability to operate tanks vertically and horizontally up to 13.5 m. The equipment of the new hall also includes:

- automatic and robot welding machine up to 4000 mm diameter and extension up to 10 m,
- automatic sheet heating and bending machine,
- the latest automatic in-line butt welder + jacket wrapping system,
- CNC plastic and composite/resin processing machine,
- production line of chemically resistant composite tanks by continuous braiding method + layers of chemically resistant plastic liner,
- tank production line with the stress-free method - coil-extruded plastic web,
- a separate stand for leakage and pressure tests,
- welding wire production line.

This allows us to perform the most complex installations.





## Tested, certified and approved materials

For the production of chemically resistant tanks, we use high-quality certified raw materials and semi-finished thermoplastic materials from SIMONA, Roechling, Georg Fischer or Agru brands, as well as granules from renowned European manufacturers (Borealis granules, Derakane Ineos resins, Huntsman). Tanks for water storage are made of materials certified by the National Institute of Hygiene.



## Compliance with restrictive standards and regulations

We manufacture tanks in accordance with current regulations and standards (especially PN-EN 12573 for thermoplastic tanks and PN-EN 13121 for composite tanks) and meet the stringent standards of DVS 2205. We carry out production based on the precise provisions of the company standard No. NZ-AM/14192/TERM/2020, which defines the best possible technology for the construction of tanks made of thermoplastics and composite materials.

# Audit, concept, design

We carry out **audits of industrial plants**, the purpose of which is to analyze and evaluate the potential and feasibility of the investment, taking into account the specifics of the technological process. A site visit allows us to collect data needed for the next steps – development of the concept and design. We audit both existing and newly built or modernized plants.

Based on the results of the audit, our engineers will develop an **implementation concept**, in which we will recommend optimal technical solutions. The concept will take into account the learned needs, as well as financial and logistical possibilities.

The next stage is the **design and calculation of tanks** based on the selected solution variant. The design study may include:

- PFD and P&ID diagrams of the process plant including tanks,
- HAZOP and LOPA analysis,
- design according to the selected model with respect to the class of detail, e.g. LOD300, LOD400,
- detailed drawings of the installation and tanks,
- work schedule, material BOM and material sheets.

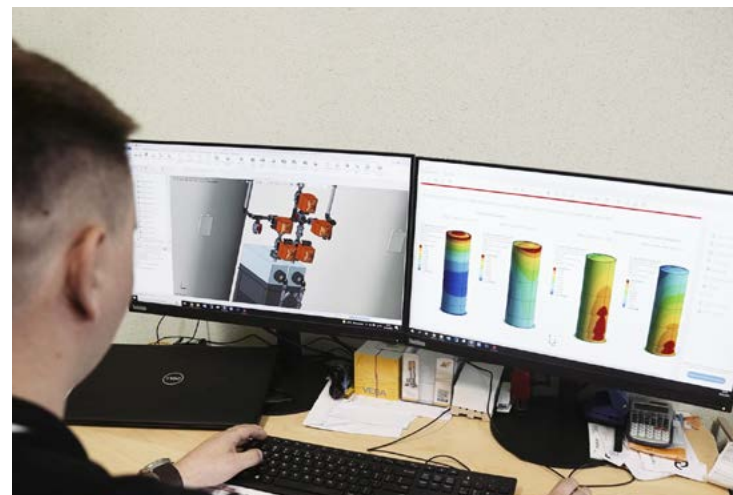

## Conversation is the key to success – free consultation

Are you facing a new challenge and unsure what solution will best meet your investment intentions? You don't have to worry, the concept stage is the best possible stage where you can explore different paths and the profitability of your investment. Don't hesitate to take advantage of a consultation, during which we will assess your problem, analyze possible solutions, help you figure out the costs and point out the right way to proceed.

# Chemical resistant aboveground tanks

We manufacture non-pressure and low-pressure tanks with a long service life, equipped with elements that reduce maintenance costs (including an indicator element, wall condition sensors and other measurement sensors to facilitate and automate operation). Depending on the application, we distinguish:

- **tanks subject to UDT supervision**, designed for the storage of corrosive, poisonous and hazardous substances, such as, among others, soda lye, hydrochloric acid, sulfuric acid, sodium hypochlorite, PIX/PAX coagulants, etc.
- **process (technological) tanks** used for processing products within production lines, including chemical resistant tanks with agitators (mixers), equipment for reducing chemical load, dosing chemicals, coagulants, acids and bases), etching baths, electroplating baths, chemical resistant reactors, etc.
- **storage tanks not subject to UDT supervision**, including tanks for non-aggressive substances such as glycol, brine, DEMI demineralized water, Clariant liquid, foaming agent, horolith, gray wastewater, post-hospital wastewater, industrial/radioactive wastewater, ionite masses, water, etc.

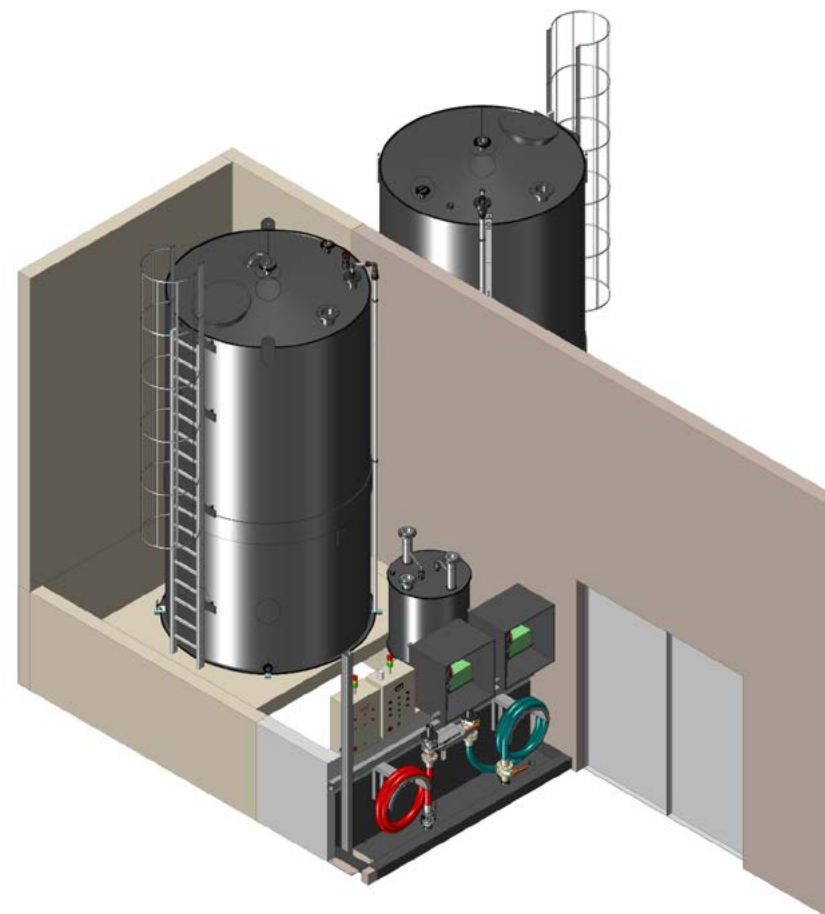

## Technologies that guarantee high resistance

The choice of tank technology is always preceded by an analysis of the medium and the operating parameters of the plant. At Amargo, we have all possible technologies for plastics and composites. In the case of plastic tanks, it can be the **AmargTank ClassicWeld®** technology for welding finished sheets of plastic with fixed commercial dimensions. Others are winding technology for thermoplastic production: **AmargTank SafeSeamLess®**, which is further divided into **AmargTank MultiLayer®** and **AmargTank MultiLayer DoubleWall®**, depending on the profile of the tank wall, and winding technology for production from composites: **AmargTank Composite®**.



*"Standard" technology using sheets of AmargTank ClassicWeld® plastic sheet*



*Winding technology (thermoplastics) AmargTank SafeSeamLess / MultiLayer / MultiLayer DoubleWall®*



*AmargTank Composite® winding technology (composites)*

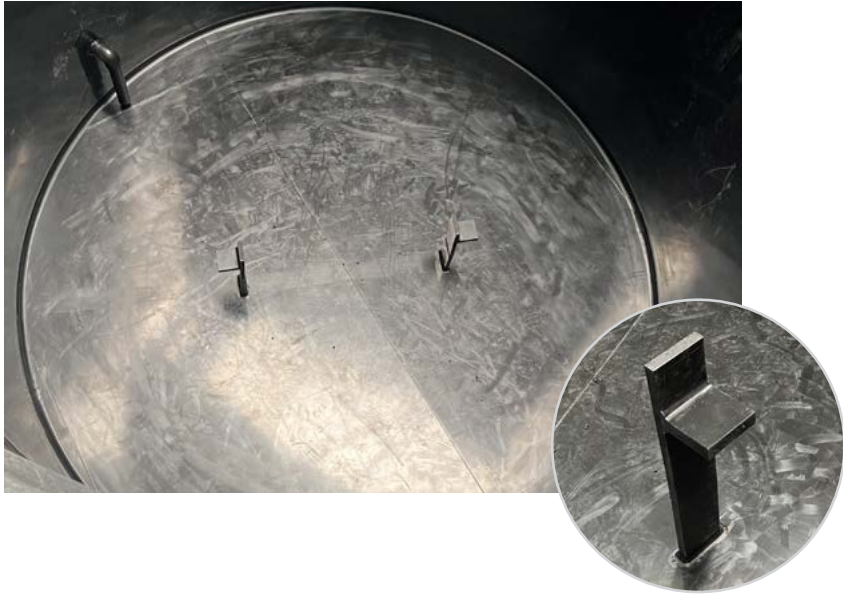

## Weld quality index to assess plastic degradation

In the design of Amargo tanks, we use an indicator element that is constructed from the same material as the tank and the same production batch. It also contains the same types of welds that were made in the tank. The indicator element works under the same conditions as the tank, so that in the framework of inspection tests it gives the inspectors of the Technical Inspection Agency, the manufacturer and the owner of the tank a substantive basis for assessing the technical condition of the structure. This allows an informed decision to extend the life of the tank.

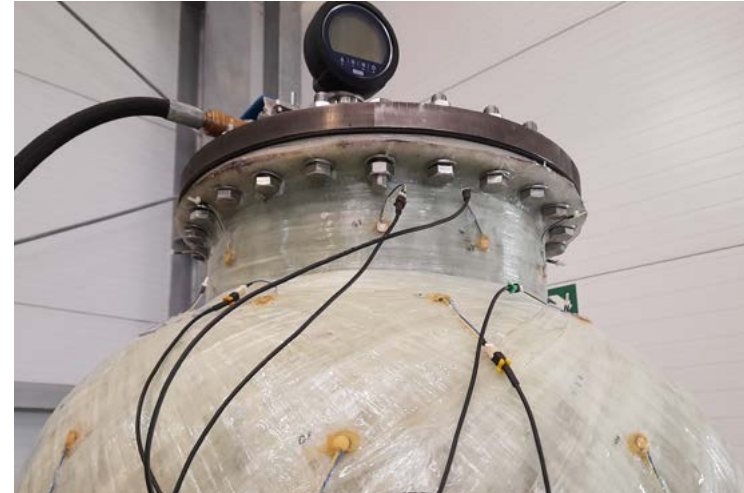

## Technologies that enable tank condition monitoring

We are constantly working on innovative solutions to meet the needs of Industry 4.0 and even 5.0. The sensor and surveillance system under development will allow full control over the chemical storage tank. This will translate into safe and reliable storage and prevent the occurrence of situations that endanger both operators and the environment. Continuous verification of the tank's condition will also enable better planning for replacement or any repairs, and ensure financial efficiency.

# Plastics used

We produce chemical resistant tanks after analyzing the working conditions. Due to their specifics, we most often use PE100, PE100 RC, PP-H, PP-C, PVC, PVC-U, PVC-C, PVDF, E-CTFE, PFA plastics, as well as GRP/TWS/FRP resins - polyester and vinylester composite structures and hybrid composite structures: chemically resistant liner and glass composite structural wall.

<p><b>HOMOGENEOUS WALL TANKS</b></p> <p>(welded from extruded sheets or tubes using stress-free filament winding technology – extruded plastic web: solid wall/structural)</p>	<ul style="list-style-type: none"> <li>• <b>PE High Density UV (PE-HD, HDPE)</b> – high density polyethylene, used for example in the manufacture of caustic soda storage tanks</li> <li>• <b>PE100 RC</b> – polyethylene characterised by high resistance to impact loads and extraordinary resistance to slow propagation of cracks (according to ISO 13479 8760 h vs. &gt;1000 h for HDPE)</li> <li>• <b>polypropylene homopolymer PP-H</b> (good chemical resistance to most organic compounds)</li> <li>• <b>polypropylene copolymer PP-C</b> (increased impact strength even at lower temperatures, range of use from -20 to +80°C)</li> <li>• <b>polyvinyl chloride</b> (also used as an insert for a tank made of another material) type PVC-U or PVC-C</li> </ul>
<p><b>LAYERED TANKS</b></p>	<ul style="list-style-type: none"> <li>• <b>PEHD outer wall, PVC insert</b></li> <li>• <b>PEHD outer wall, PVDF/E-CTFE insert</b> – for cost reasons they are used in low thicknesses as liners, e.g., from 2-3 to max. 4 mm</li> </ul>
<p><b>COMPOSITE TANKS</b></p>	<ul style="list-style-type: none"> <li>• <b>glass fibre reinforced chemical resistant resins (GRP, FRP, GRP):</b> <ol style="list-style-type: none"> <li>a) resin system covered with a finishing layer</li> <li>b) multi-layer structures, e.g., inner liner made of PE, PP, PVC, PVDF, E-CTFE, PFA (providing extremely high chemical and temperature resistance) + as a composite structure with high corrosion and chemical resistance</li> </ol> </li> </ul>



## Protection of tanks against leakage of substances

We additionally protect tanks working with corrosive and hazardous substances from leakage of the medium due to unsealing or overflow / overfilling, protecting the production environment and the environment.

We equip tanks with liquid level indicators (non-contact measurement probes: ultrasonic or radar with signal retransmission option and float

level gauges), as well as overfill sensors in accordance with udt requirements.

In addition, we select technically and economically optimal security solutions, which are:

- a **second wall in the tank structure**, acting as a spillage container (so-called bunded tank),
- **tank in the protection and spillage container** –

thanks to this protection, the floors of production halls and drainage drains are protected,

- **shell with leakage monitoring system.**

In the case of tanks that are not under the supervision of the Technical Inspection Authority, the method of securing them is regulated by occupational health and safety regulations and the conditions prevailing at the plant.

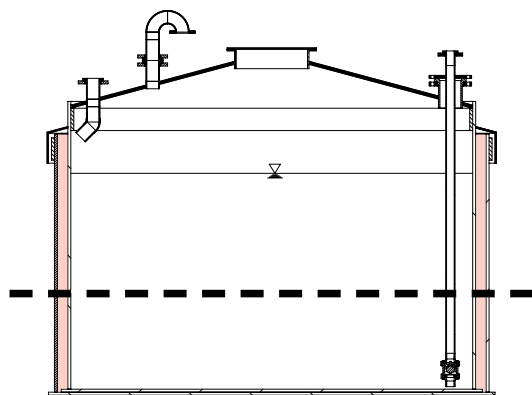

01

Double-walled tank (second jacket in the tank structure)



02

Tanks in the protection and spillage container

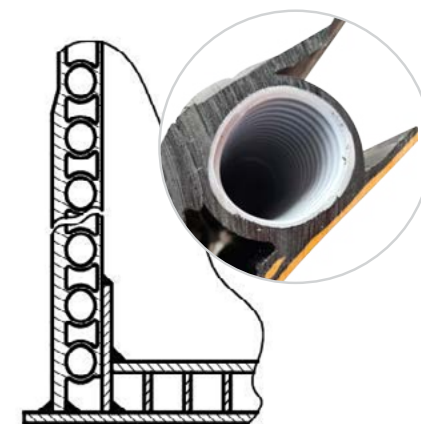

03

Shell with leakage monitoring system

## Tank accessories

Depending on the type of stored or processed substance or mixture of chemical compounds, we equip the tank with necessary fittings and various installation components that are selected individually, depending on the purpose of the tank and the client's needs. In the table below you will find a summary of the equipment - both standard, which are ports in the appropriate configuration, hatches, sensors, as well as additional, such as heating systems.

Tank components	Safety fittings
<ul style="list-style-type: none"> <li>• Roof hatches, side hatches, sight glasses</li> <li>• Necessary ports (inlet/outlet, connectors, etc.)</li> <li>• Ladders, service platforms, gangways, gratings, railings, lighting, signage</li> <li>• Ground fixing systems, wind protection</li> </ul>	<ul style="list-style-type: none"> <li>• Liquid level indicators (non-contact measurement probes: ultrasonic or radar with signal retransmission option and float level gauges)</li> <li>• Overfill and leakage sensors according to UDT requirements</li> <li>• Flow measurement elements</li> <li>• Heating systems in the form of chemical resistant heaters or surface heating (redundant systems if necessary)</li> <li>• Automatic control, measurement and control systems (control cabinets, actuators, throttles, valves)</li> </ul>



## Benefits of plastic chemical resistant tanks



### In accordance with legal requirements

The proposed solutions allow us to meet the requirements of the Polish Standards and technical specifications of the Office of Technical Inspection. In the case of metered storage tanks, we support in the course of the UDT procedure.



### Safety of chemical storage

The high chemical resistance of the certified plastics, as well as the airtight and hermetic design of the tanks, will ensure safe and proper storage and dispensing of chemicals. In addition, the plastics used are certified by the National Institute of Hygiene (Poland).



### Reliability and economic efficiency

Our holistic approach to investment, analysis of risks and use of dedicated system components depending on the medium and operating conditions of the plant will help ensure the continuity and reliability of the system and the processes carried out.



### Operational savings

Optimizing operating expenses and costly refurbishments is a priority for many plants. Achieving these goals is possible thanks to the favorable properties of the plastics, the elimination of corrosion risks, long-life tank design, automation of the process and readings, and tank condition indicator elements.



### Occupational health and safety and protection of plant personnel

Thanks to the use of appropriate safeguards for the chemical-resistant tank, plant personnel and the environment are protected from the consequences of any leakage. In turn, the implementation of a medium unloading and batching plant with full automation allows to ensure a controlled and safe process, resulting in reliability, efficiency and high quality production.



### Environmental impact

Amargo's reservoirs are part of the European Green Deal, reduction of CO<sub>2</sub> emissions, reduction of pollution levels, decarbonization, closed-loop economy, use of hydrogen or the battery industry. We are currently researching the possibility of using green, low-emission, styrene-free resins.

# Comprehensive industrial installations

Ordering a comprehensive turnkey service including acceptance, commissioning and commissioning tests from one company saves time and ensures investment security. We provide you with the certainty of execution and operation of the entire system (from the place of unloading – feeding the tank to the place of delivery of the medium).

We carry out industrial installations including hooking up the tanks to the whole system and commissioning:

- **transmission installations** – from UNO stations to the tank,
- **dispensing installations** – from the dispensing tank to the plant,
- **ventilation and vapor encapsulation,**
- **NO stations/systems** including acceptance of Transport Technical Supervision (TDT),
- **cabling, automation and control,** IOT, data transmission and interfacing with systems running on the industrial plant.

Plant components also include metering pumps, mixers, feeders and hoppers for bulk products, or suction aids (automatic/manual), among others.



## Media transfer and dispensing installations

In addition to the tanks themselves, along with instrumentation, we carry out the installation of the system filling the tanks and dosing from the tanks to the process line. Depending on the specifics of the project, among the elements of the executed substance transfer and dosing installations are double-walled plastic chemical-resistant pipelines, chemical-resistant transfer and unloading pumps, manual, automatic and venting and aerating valves, AKiP cabinets.



## Equipment for filling and emptying tanks (UNO)

We implement filling and emptying equipment for hazardous liquids stored in our tanks, including ammonia water, sodium hypochlorite, soda lye, hydrochloric acid, nitric acid, sulfuric acid, oxygenated water and others. As part of the investment, we provide the design of the UNO loading station, preparation and agreement of documentation (technical + registration) for the Transport Technical Supervision unit TDT, as well as delivery and installation on the site.

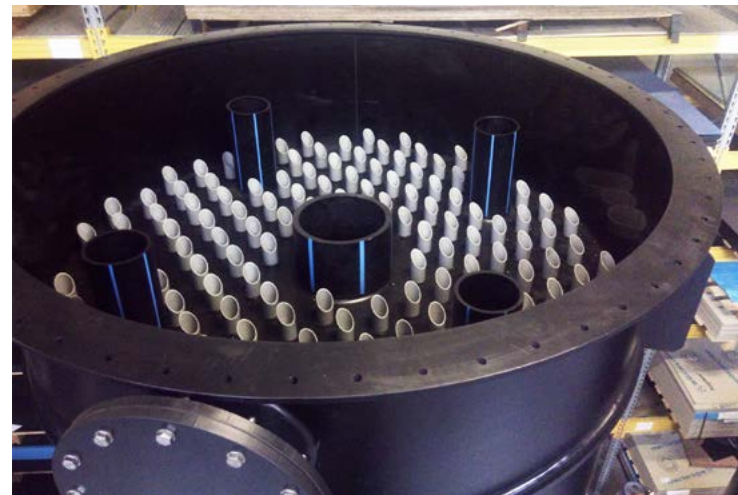

## Ventilation of tanks – purification of air and gases

We produce efficient apparatuses and systems for neutralization of gases and odors – according to the project preceded by gas analysis and selection of the appropriate treatment system and equipment size. For the discharge of poisonous and corrosive vapors from the tank we use chemically resistant channels made of resistant materials (including PVC, PE, PP, PPs, PE-EL or PPs-EL). For protection against exceeding the emission of vapors from above the tanks we make water scrubbers.

## Process tanks with installations to ensure business growth

Implementation of a development plan involving the production of a new product range at a cosmetics manufacturer – for this reason, a new technological line was created at the company



### SCOPE OF WORKS

- Process tank for aqueous sodium chloride solution and intermediate tanks for Betaine and Aluminum Zirconium
- Substance transfer and dosing installations

## Changing the storage and transfer of the medium in the production line

Optimize costs in the purchase and supply of the medium and in the operation of distribution and process, increase the level of safety and reduce the risk of accidents



### SCOPE OF WORKS

- A storage tank with an active capacity of 31 m<sup>3</sup> and a technological tank with an active capacity of m<sup>3</sup>
- Substance transfer and dosing installations

## New UDT surveillance tanks for NaOH and HCl with weld quality indicators

Ensure production continuity by replacing depleted metering tanks with exceeded life expectancy



### SCOPE OF WORKS

- Storage tanks subject to UDT supervision for NaOH and HCl, equipped with weld quality indicators
- HCl hydrochloric acid vapor absorber
- Equipment for filling and emptying tanks

## NaOH 50% storage tank with unloading and medium transfer facilities

Expansion of the plant to increase production (including cleaning stations for production facilities), which involved an increase in demand for soda lye)



### SCOPE OF WORKS

- Double-walled storage tank with a capacity of 30 m<sup>3</sup>
- Medium transfer installation
- Modernization of Tank Filling and Emptying Equipment

## Internal supervision tanks UDT storage tanks for hydrochloric acid HCl with installations

Construction of a new concentrated HCl storage and dosing facility resulting from the expansion of the plant, where large-capacity tanks have not previously been used



### SCOPE OF WORKS

- Equipping 2 production lines with a total of 4 storage tanks
- Installation of emptying of the tank
- Discharge of hazardous fumes

## Tanks for transfusion of ionite masses (anionite and cationite) for water treatment plants

Optimization of costs by subjecting used ionite masses to a recycling process (bed regeneration) - previously used masses were not purified and went entirely to the "trash"



### SCOPE OF WORKS

- 4 tanks with capacities from 5.5 m<sup>3</sup> to 11 m<sup>3</sup> equipped with, among other things, an injector (injector), a slotted star grate, sight glasses and a set of connections of the "cam-lock" type



*Intermediate tanks for Betaine and Aluminum Zirconium with installations*



*PE100 tanks of 24 m<sup>3</sup> each for storage of Clariant fluid*



*Laminated plastic tanks for laboratory liquid waste and low-level waste water*



*Process tanks (pickling tanks) with equipment and piping for automated production line of metal parts*



# Indoor modular water storage tanks

We offer internal non-pressure water tanks on a design-build basis for industrial plants and public facilities:

- **fire tanks** for storing water used for firefighting purposes,
- **reserve/potable water tanks** to provide minimum quantities of water for social and domestic purposes, mainly in medical facilities (in accordance with the Decree of the Minister of Health of March 26, 2019 [1]),
- **retention tanks** for rainwater (rainwater tanks),
- **buffer tanks** to provide an adequate supply of water for production purposes or to reuse water from technological/production processes and water treatment.

[1] Regulation of the Minister of Health of March 26, 2019 on detailed requirements to be met by the premises and equipment of an entity performing medical activities

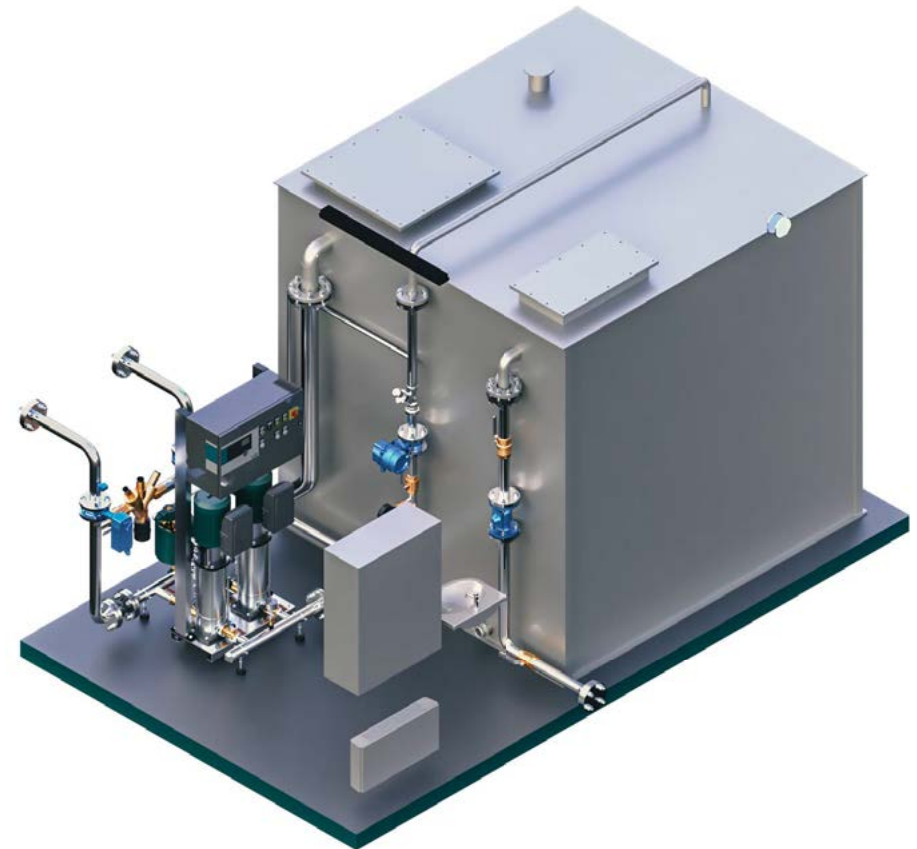

## AmargTank MultiPower® tank design

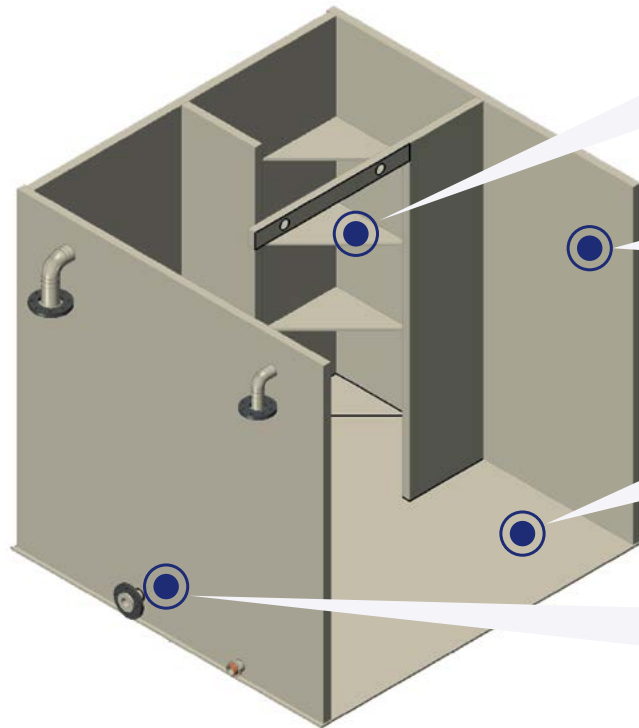

The structure of the tank is a cuboidal shell, which is further reinforced with plates welded inside at 90° – so there is no need for additional steel profiles.

The walls of the tank are made of prefabricated modular (ribbed, sandwich) MultiPower/Polystone CubX panels made of resistant PP-COPO, HDPE or PP-H plastic with dimensions of 2600 × 1000 mm and thickness of 50/57 mm.

The bottom and lid (ceiling) of the tank are made of solid board, such as PP or HDPE.

Modular tanks are additionally equipped with spigots, connections, supply pipelines, gate valves and valves, control systems, water level measurement and communication with central control systems installed in buildings.

If the foundation conditions allow it, the tank is made in our manufacturing plant and then delivered to the site. However, most of the realizations are inside existing buildings, where there is no possibility to bring the tank in its entirety – often access to the room, for example, the pump room is through narrow corridors and doors. In such cases, construction is carried out on site.

## Practical benefits of modular water tanks



### Highest hygiene standards

The construction material of the tank is approved by the PZH and has good thermal insulation ( $1.7 \text{ W m}^2 \times \text{K}$ ). Heat-insulating walls reduce the heating of the water, thereby reducing the development and multiplication of bacteria.



### Operational savings

The design of the AmargTank MultiPower® is free of steel components that can corrode. As a result, the tank does not require cyclic, time-consuming and costly maintenance.



### Long-term durability of the tank

Thanks to high wear resistance, high resistance to cracking, and negligible water absorption, the user gains many years of tank life without the risk of leakage and flooding of the room.



### No costly interference with the building structure

Thanks to the possibility of realizing on-site assembly from individual modules, there is no need to interfere with the structure of the building (such as demolishing walls or widening doorways) – it is enough that there are no permanent obstacles in the way of bringing the elements, i.e. the plates for tank assembly.



### Reducing the cost of servicing fire installations

Ensuring the purity of the water reduces secondary contamination of fire system components (water mist extinguishing) and avoids the penetration of dirt into small-diameter nozzles (in the case of steel tanks, these can become clogged with filings and metal particles, posing a risk of improper operation of the installation).



### Comfort during daily use of the tank

Making the tank of plastic plates makes it easier for maintenance services to clean it through unlimited disinfection and pressure washing of the tank, in turn, the low weight makes it easier to operate (opening the large, rigid, yet lightweight tank lid will not be cumbersome).

# The potential of BIM technology

Design processes are increasingly based on data and digital solutions, so as a tank manufacturer we are focused on implementing measures to support the work of both designers and contractors. **Modular tanks mapped in the BIM standard (in the Revit application) are the answer to current trends and the high requirements of the installation industry.**



## Optimization of project work time

Increase the standard and efficiency of design work with ready-made design specification descriptions and visualizations.



## Verification of the feasibility of the tank

Dedicated filters that allow efficient verification of the possibility of making a tank with the established technical parameters.



## Modification of tank variants

BIM models make it possible to quickly configure the solution and model different options depending on investment needs.



## Ability to generate bills of materials of materials

A number of so-called “shared parameters” allow generating unambiguous and readable bills of materials - both for the needs of the industry guidelines attached to the project documentation, pre-invoice books, and commercial orders.



## Predicting investment risk

BIM technology makes it possible to estimate potential risks at an early stage and facilitates the analysis of possible paths for solving emerging problems. This offers the prospect of reducing costs and having a real impact on the course of a construction project.



## Streamlining the investment process

Revit libraries optimize the design process according to the developer’s guidelines and in accordance with technical possibilities. Precise design enables quick quotation from the manufacturer and determination of the work schedule. This streamlines the bidding process and implementation.

## Water reserve tank with a capacity of 162.5 m<sup>3</sup> for the hospital

Provide a source of drinking water supply in the hospital facility in accordance with the Regulations of the Minister of Health and adapt to the unusual shape of the room



### SCOPE OF WORKS

- Design and construction of a drinking water tank with an unusual "L" shape

## Mountain shelter fire water tank

Provide water storage for the water mist extinguishing system in the pump room of the shelter located at an altitude of 1,670 meters above sea level.



### SCOPE OF WORKS

- Modular tank with a usable capacity of 6 m<sup>3</sup>

## Utilization of post-production water thanks to modular tank

Cost optimization through improved water and wastewater management (reduced consumption of mains water and reuse of wash water)



### SCOPE OF WORKS

- A washwater clarifier with a total capacity of 104.5 m<sup>3</sup>



*Fire tank for the archive building*



*Water reserve tank with a capacity of 10 m<sup>3</sup> for the hospital*



*Fire tank of 18 m<sup>3</sup> for the office building*



*Drinking water storage tank for health center*

# Underground pipe tanks

We manufacture horizontal cylindrical tanks for underground or partially sunken foundation. The tanks are manufactured from PE-HD/PP plastic, with a double-wall winding pipe with a diameter of 1000 to 4000 mm, with a profile section. Depending on the application and needs, we equip them with chimneys with manholes and lids, leak detection systems for the inter-panel space, level measurement sensors, fill signaling, etc.

## Underground tanks are designed for:

- storage of chemicals, leachate, drainage of medium from installations, etc.,
- use as leachate clarifiers,
- storage of drinking water (including system solutions, i.e., tank battery and technical chambers with pumps, gate valves, etc.).

## Key features of underground tanks:

- wide range of chemical resistance,
- temperature resistance from  $-30^{\circ}\text{C}$  to  $+60^{\circ}\text{C}$ ,
- circumferential stiffness SN2/SN4/SN8/other according to the design,
- can be used in road lanes and under parking lots.



# Service of tanks and installations

Do not neglect regular maintenance. Servicing industrial plastic tanks is not only about doing your duty and ensuring safety, but also about a number of other operational or financial benefits.

Let's not kid ourselves – system and tank malfunctions do happen. However, they don't have to mean the end of the world. It is the down-playing of regular servicing that often makes them noticed only when a major failure is already on the horizon...

Regardless of the purpose of the tank, performing regular technical maintenance indicated at the time specified by the manufacturer keeps tanks in good shape, and thus ensures safety, extends their life and minimizes the risk of failure and potential costs.



## IMPORTANT

We are currently carrying out service work only in Poland. However, the information is useful regardless of the country of use of industrial tanks.



## Reduce risk and save time

Systematic monitoring of tank performance and implementation of a maintenance schedule allows to maintain high efficiency and ensure safe and reliable operation. In the long term, it influences the reduction of plant maintenance costs.

Outsourcing tank service, inspections and repairs to a qualified team reduces risk and saves time – we know more about plastic tanks than anyone else. When outsourcing service, verify that the contractor has professional equipment to service complex and demanding installations, entrances to all types of tanks, including gas and vapor detectors, gas masks, air supply systems, safety harnesses, etc.



# Chemical protection

We make **chemical-resistant linings** for both depleted and newly constructed steel or reinforced concrete tanks. Protection guarantees resistance to corrosive substances, eliminates the risk of corrosion, and thus extends the life of the structure. Sealing with a plastic lining makes it possible to optimize implementation costs and realize installation work in the shortest possible downtime.

Chemical protection is implemented by means of:

- **PE High Density UV plastic liners** (PE-HD, HDPE) that guarantee full tightness and impermeability of the bottom and shell of the tank / tub,
- **fluoropolymer plates** (PVDF, E-CTFE, PFA, PTFE lamination plates) providing chemical resistance to the most severe chemistry (e.g., 98% sulfuric acid) and temperature (up to 150°C),
- **wear-resistant liners** made of ready-made PE1000 UHMW skid plates (for silos and chutes).

In addition, we provide technical advice, the selection of chemical resistance for specific applications, as well as comprehensive execution of **drip trays** (in other words, protection and lifting) for tanks, machines, pumps pumping chemicals.



# Cylinders, plastic pipes – mass production

In addition to tanks, we offer in series production stress-free pipes, channels and cylinders for individualized needs and parameters. All based on AmargTank's SafeSeamLess® technology, through which we can provide you with, among other things, cost optimization and more technical possibilities not offered by ordinary solid plastic sheets. We realize, among other things:

- pipes for installation systems,
- elements of ventilation systems / chimneys chemically resistant with large cross sections, used in aggressive industrial environments,
- chemically resistant and non-corrosive housings / technical chambers of pumping stations, separators, intended for fittings and technological equipment (pumping systems, control, filters).

Possible parameters:

- diameter range: 1000÷4000 mm,
- length range: up to 10÷13 m,
- monolithic single-body or multi-body construction,
- temperature resistance range: from -30°C ÷ +60°C,
- high service life of systems.



# Tank Education TAED Academy – education based on experience and practical knowledge

The smooth running of an investment is certainly what you care about - whether you are a designer, investor or contractor. However, you don't need to know everything and be familiar with everything – it's insanely difficult! That's why we come to help. We share with you practical knowledge in the field of plastic tanks and installations for chemicals and water. **Thanks to our experience and ongoing educational activities, you will develop the competencies that will allow you to meet your investment goals in accordance with current standards and taking into account the most important technical aspects.**



**Designer zone: technical specifications, design tips**

The Designer's Zone is useful materials for recognizing problems and solving technical challenges through the use of modern technologies. Here you will find, among other things, explanations of design and calculation dependencies, ranges of application of individual materials and technologies, standards on the basis of which individual tanks and installations are made.



**Educational base: tutorials, articles, videos, podcast**

Amargo's educational base is a collection of substantive publications and case studies, in which we address issues such as legal regulations, cost optimization, technological solutions and the possibilities and limitations of plastics. It is also a compendium of knowledge collected in the formula of PREMIUM guides. We share all the materials successively in our newsletter.



**Onsite and online training, webinars**

We carry out training dedicated to design offices, representatives of the industry, inspectors of regulatory agencies and certification bodies. During the meetings we cover not only legal aspects, but above all we focus on providing information to improve the course of the investment and practical knowledge in the field of design, production and operation of tanks.



**IMPORTANT:** most educational activities are carried out in Polish. If you are looking for specific tips to expand your competence or solve a problem, please email us at [akademia@amargo.pl](mailto:akademia@amargo.pl)



[www.amargo.pl/en](http://www.amargo.pl/en)